

± 2% NEGATIVE VOLTAGE REGULATORS

- OUTPUT CURRENT UP TO 1.5A
- OUTPUT VOLTAGES OF -5; -5.2; -6; -8; -12; -15; -18; -20; -22; -24V
- THERMAL CIRCUIT PROTECTION
- OUTPUT TRANSISTOR SOA PROTECTION

DESCRIPTION

The L7900A series of three-terminal negative regulators is available in TO-220 package and with several output voltages. They can provide local on-card regulation, eliminating the distribution problems associated with single point regulation ; furthermore, having the same voltage options as the L7800 positive standard series, they are particularly suited for split power supplies. In addition, the -5.2V is also available for ECL system.

If adequate heatsinking is provided, the L7900A series can deliver an output current in excess of 1.5A. Although designed primarily as fixed voltage regulators, these devices can be used with external components to obtain adjustable voltages and currents.

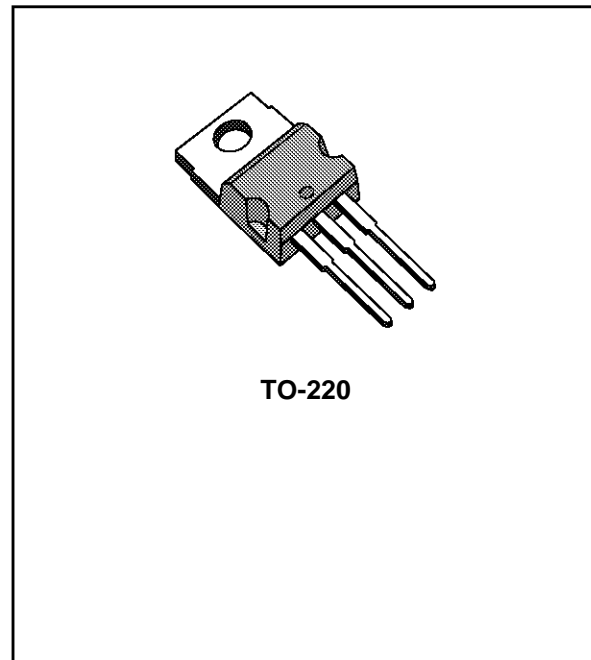

SCHEMATIC DIAGRAM

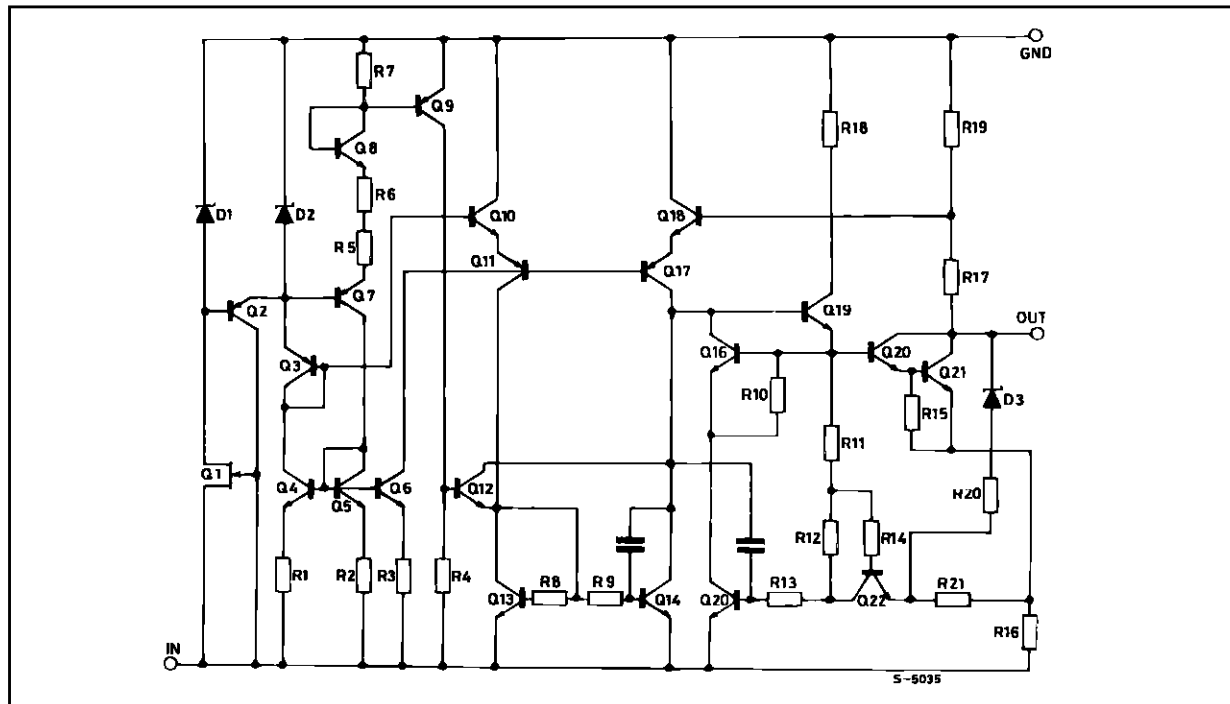

L7900AB/AC SERIES

ABSOLUTE MAXIMUM RATING

Symbol	Parameter	Value	Unit
V_i	DC Input Voltage (for $V_o = -5$ to -18 V) (for $V_o = -20, -24$)	-35 -40	V V
I_o	Output Current	Internally Limited	
P_{tot}	Total Power Dissipation	Internally Limited	
T_{op}	Operating Junction Temperature for L7900AC for L7900AB	0 to 125 -40 to 125	°C
T_{stg}	Storage Temperature	-65 to 150	°C

THERMAL DATA

$R_{thj-case}$	Thermal Resistance Junction-Case	Max	3	°C/W
$R_{thj-amb}$	Thermal Resistance Junction-Ambient	Max	50	°C/W

CONNECTION DIAGRAM AND ORDERING NUMBERS (top views)

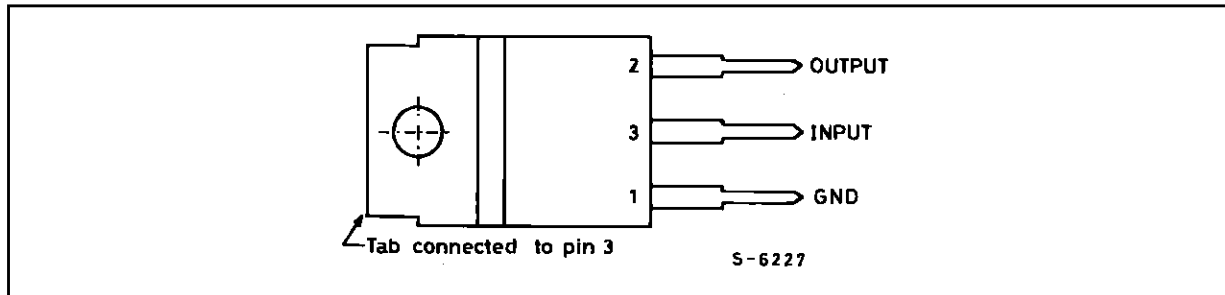

TYPE	TO-220	TO-220	OUTPUT VOLTAGE
	$T_j = -40$ to 125 °C	$T_j = 0$ to 125 °C	
L7905A	L7905ABV	L7905ACV	-5 V
L7952A	L7952ABV	L7952ACV	-5.2 V
L7906A	L7906ABV	L7906ACV	-6 V
L7908A	L7908ABV	L7908ACV	-8 V
L7912A	L7912ABV	L7912ACV	-12 V
L7915A	L7915ABV	L7915ACV	-15 V
L7818A	L7818ABV	L7818ACV	-18 V
L7920A	L7920ABV	L7920ACV	-20 V
L7922A	L7922ABV	L7922ACV	-22 V
L7924A	L7924ABV	L7924ACV	-24 V

APPLICATION CIRCUIT

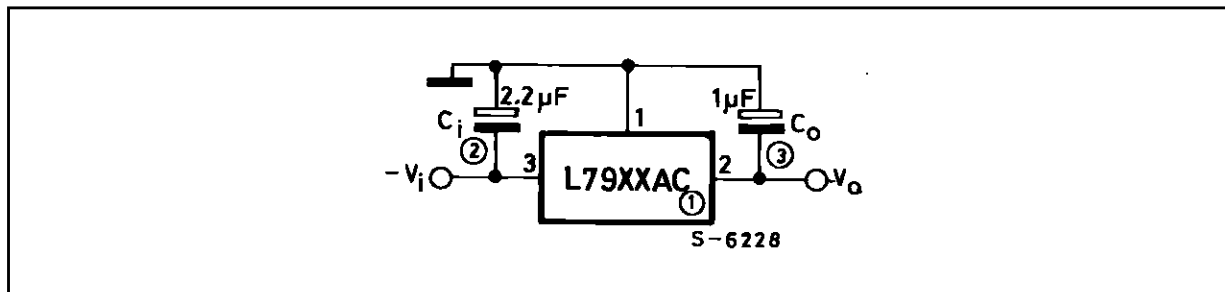

ELECTRICAL CHARACTERISTICS FOR L7905A (refer to the test circuits, $T_j = 0$ to 125 °C, $V_i = -10V$, $I_o = 500$ mA, $C_i = 2.2$ μ F, $C_o = 1$ μ F unless otherwise specified)

Symbol	Parameter	Test Conditions	Min.	Typ.	Max.	Unit
V_o	Output Voltage	$T_j = 25$ °C	-4.9	-5	-5.1	V
V_o	Output Voltage	$I_o = -5$ mA to -1 A $P_o \leq 15$ W $V_i = -8$ to -20 V	-4.8	-5	-5.2	V
ΔV_o^*	Line Regulation	$V_i = -7$ to -25 V $T_j = 25$ °C $V_i = -8$ to -12 V $T_j = 25$ °C			100 50	mV mV
ΔV_o^*	Load Regulation	$I_o = 5$ to 1500 mA $T_j = 25$ °C $I_o = 250$ to 750 mA $T_j = 25$ °C			100 50	mV mV
I_d	Quiescent Current	$T_j = 25$ °C			3	mA
ΔI_d	Quiescent Current Change	$I_o = 5$ to 1000 mA			0.5	mA
ΔI_d	Quiescent Current Change	$V_i = -8$ to -25 V			1.3	mA
$\frac{\Delta V_o}{\Delta T}$	Output Voltage Drift	$I_o = 5$ mA		-0.4		mV/°C
e_N	Output Noise Voltage	$B = 10$ Hz to 100 KHz $T_j = 25$ °C		100		μ V
SVR	Supply Voltage Rejection	$\Delta V_i = 10$ V $f = 120$ Hz	54	60		dB
V_d	Dropout Voltage	$I_o = 1$ A $T_j = 25$ °C $\Delta V_o = 100$ mV		1.4		V
I_{sc}	Short Circuit Current			2.1		A
I_{scp}	Short Circuit Peak Current	$T_j = 25$ °C		2.5		A

ELECTRICAL CHARACTERISTICS FOR L7952A (refer to the test circuits, $T_j = 0$ to 125 °C, $V_i = -10V$, $I_o = 500$ mA, $C_i = 2.2$ μ F, $C_o = 1$ μ F unless otherwise specified)

Symbol	Parameter	Test Conditions	Min.	Typ.	Max.	Unit
V_o	Output Voltage	$T_j = 25$ °C	-5.1	-5.2	-5.3	V
V_o	Output Voltage	$I_o = -5$ mA to -1 A $P_o \leq 15$ W $V_i = -9$ to -21 V	-5	-5.2	-5.4	V
ΔV_o^*	Line Regulation	$V_i = -8$ to -25 V $T_j = 25$ °C $V_i = -9$ to -13 V $T_j = 25$ °C			105 52	mV mV
ΔV_o^*	Load Regulation	$I_o = 5$ to 1500 mA $T_j = 25$ °C $I_o = 250$ to 750 mA $T_j = 25$ °C			105 52	mV mV
I_d	Quiescent Current	$T_j = 25$ °C			3	mA
ΔI_d	Quiescent Current Change	$I_o = 5$ to 1000 mA			0.5	mA
ΔI_d	Quiescent Current Change	$V_i = -9$ to -25 V			1.3	mA
$\frac{\Delta V_o}{\Delta T}$	Output Voltage Drift	$I_o = 5$ mA		-0.5		mV/°C
e_N	Output Noise Voltage	$B = 10$ Hz to 100 KHz $T_j = 25$ °C		125		μ V
SVR	Supply Voltage Rejection	$\Delta V_i = 10$ V $f = 120$ Hz	54	60		dB
V_d	Dropout Voltage	$I_o = 1$ A $T_j = 25$ °C $\Delta V_o = 100$ mV		1.4		V
I_{sc}	Short Circuit Current			2.1		A
I_{scp}	Short Circuit Peak Current	$T_j = 25$ °C		2.5		A

* Load and line regulation are specified at constant junction temperature. Changes in V_o due to heating effects must be taken into account separately. Pulse testing with low duty cycle is used.

L7900AB/AC SERIES

ELECTRICAL CHARACTERISTICS FOR L7906A (refer to the test circuits, $T_j = 0$ to 125 °C, $V_i = -11V$, $I_o = 500$ mA, $C_i = 2.2$ μ F, $C_o = 1$ μ F unless otherwise specified)

Symbol	Parameter	Test Conditions	Min.	Typ.	Max.	Unit
V_o	Output Voltage	$T_j = 25$ °C	-5.88	-6	-6.12	V
V_o	Output Voltage	$I_o = -5$ mA to -1 A $P_o \leq 15$ W $V_i = -9.5$ to -21.5 V	-5.76	-6	-6.24	V
ΔV_o^*	Line Regulation	$V_i = -8.5$ to -25 V $T_j = 25$ °C $V_i = -9$ to -15 V $T_j = 25$ °C			120 60	mV mV
ΔV_o^*	Load Regulation	$I_o = 5$ to 1500 mA $T_j = 25$ °C $I_o = 250$ to 750 mA $T_j = 25$ °C			120 60	mV mV
I_d	Quiescent Current	$T_j = 25$ °C			3	mA
ΔI_d	Quiescent Current Change	$I_o = 5$ to 1000 mA			0.5	mA
ΔI_d	Quiescent Current Change	$V_i = -9.5$ to -25 V			1.3	mA
$\frac{\Delta V_o}{\Delta T}$	Output Voltage Drift	$I_o = 5$ mA		-0.6		mV/°C
e_N	Output Noise Voltage	$B = 10$ Hz to 100 KHz $T_j = 25$ °C		144		μ V
SVR	Supply Voltage Rejection	$\Delta V_i = 10$ V $f = 120$ Hz	54	60		dB
V_d	Dropout Voltage	$I_o = 1$ A $T_j = 25$ °C $\Delta V_o = 100$ mV		1.4		V
I_{sc}	Short Circuit Current			2		A
I_{scp}	Short Circuit Peak Current	$T_j = 25$ °C		2.5		A

ELECTRICAL CHARACTERISTICS FOR L7908A (refer to the test circuits, $T_j = 0$ to 125 °C, $V_i = -14V$, $I_o = 500$ mA, $C_i = 2.2$ μ F, $C_o = 1$ μ F unless otherwise specified)

Symbol	Parameter	Test Conditions	Min.	Typ.	Max.	Unit
V_o	Output Voltage	$T_j = 25$ °C	-5.1	-5.2	-5.3	V
V_o	Output Voltage	$I_o = -5$ mA to -1 A $P_o \leq 15$ W $V_i = -11.5$ to -23 V	-5	-5.2	-5.4	V
ΔV_o^*	Line Regulation	$V_i = -10.5$ to -25 V $T_j = 25$ °C $V_i = -11$ to -17 V $T_j = 25$ °C			160 80	mV mV
ΔV_o^*	Load Regulation	$I_o = 5$ to 1500 mA $T_j = 25$ °C $I_o = 250$ to 750 mA $T_j = 25$ °C			160 80	mV mV
I_d	Quiescent Current	$T_j = 25$ °C			3	mA
ΔI_d	Quiescent Current Change	$I_o = 5$ to 1000 mA			0.5	mA
ΔI_d	Quiescent Current Change	$V_i = -11.5$ to -25 V			1	mA
$\frac{\Delta V_o}{\Delta T}$	Output Voltage Drift	$I_o = 5$ mA		-0.8		mV/°C
e_N	Output Noise Voltage	$B = 10$ Hz to 100 KHz $T_j = 25$ °C		175		μ V
SVR	Supply Voltage Rejection	$\Delta V_i = 10$ V $f = 120$ Hz	54	60		dB
V_d	Dropout Voltage	$I_o = 1$ A $T_j = 25$ °C $\Delta V_o = 100$ mV		1.1		V
I_{sc}	Short Circuit Current			1.5		A
I_{scp}	Short Circuit Peak Current	$T_j = 25$ °C		2.5		A

* Load and line regulation are specified at constant junction temperature. Changes in V_o due to heating effects must be taken into account separately. Pulse testing with low duty cycle is used.

ELECTRICAL CHARACTERISTICS FOR L7912A (refer to the test circuits, $T_j = 0$ to 125 °C, $V_i = -19V$, $I_o = 500$ mA, $C_i = 2.2$ μF , $C_o = 1$ μF unless otherwise specified)

Symbol	Parameter	Test Conditions	Min.	Typ.	Max.	Unit
V_o	Output Voltage	$T_j = 25$ °C	-11.75	-12	-12.75	V
V_o	Output Voltage	$I_o = -5$ mA to -1 A $P_o \leq 15$ W $V_i = -15.5$ to -27 V	-11.5	-12	-12.5	V
ΔV_o^*	Line Regulation	$V_i = -14.5$ to -30 V $T_j = 25$ °C $V_i = -16$ to -22 V $T_j = 25$ °C			240 120	mV mV
ΔV_o^*	Load Regulation	$I_o = 5$ to 1500 mA $T_j = 25$ °C $I_o = 250$ to 750 mA $T_j = 25$ °C			240 120	mV mV
I_d	Quiescent Current	$T_j = 25$ °C			3	mA
ΔI_d	Quiescent Current Change	$I_o = 5$ to 1000 mA			0.5	mA
ΔI_d	Quiescent Current Change	$V_i = -15$ to -25 V			1	mA
$\frac{\Delta V_o}{\Delta T}$	Output Voltage Drift	$I_o = 5$ mA		-0.8		mV/°C
e_N	Output Noise Voltage	$B = 10$ Hz to 100 KHz $T_j = 25$ °C		200		μV
SVR	Supply Voltage Rejection	$\Delta V_i = 10$ V $f = 120$ Hz	54	60		dB
V_d	Dropout Voltage	$I_o = 1$ A $T_j = 25$ °C $\Delta V_o = 100$ mV		1.1		V
I_{sc}	Short Circuit Current			2.1		A
I_{scp}	Short Circuit Peak Current	$T_j = 25$ °C		2.5		A

ELECTRICAL CHARACTERISTICS FOR L7915A (refer to the test circuits, $T_j = 0$ to 125 °C, $V_i = -23V$, $I_o = 500$ mA, $C_i = 2.2$ μF , $C_o = 1$ μF unless otherwise specified)

Symbol	Parameter	Test Conditions	Min.	Typ.	Max.	Unit
V_o	Output Voltage	$T_j = 25$ °C	-14.7	-15	-15.3	V
V_o	Output Voltage	$I_o = -5$ mA to -1 A $P_o \leq 15$ W $V_i = -18.5$ to -30 V	-14.4	-15	-15.6	V
ΔV_o^*	Line Regulation	$V_i = -17.5$ to -30 V $T_j = 25$ °C $V_i = -20$ to -26 V $T_j = 25$ °C			300 150	mV mV
ΔV_o^*	Load Regulation	$I_o = 5$ to 1500 mA $T_j = 25$ °C $I_o = 250$ to 750 mA $T_j = 25$ °C			300 150	mV mV
I_d	Quiescent Current	$T_j = 25$ °C			3	mA
ΔI_d	Quiescent Current Change	$I_o = 5$ to 1000 mA			0.5	mA
ΔI_d	Quiescent Current Change	$V_i = -18.5$ to -30 V			1	mA
$\frac{\Delta V_o}{\Delta T}$	Output Voltage Drift	$I_o = 5$ mA		-0.9		mV/°C
e_N	Output Noise Voltage	$B = 10$ Hz to 100 KHz $T_j = 25$ °C		250		μV
SVR	Supply Voltage Rejection	$\Delta V_i = 10$ V $f = 120$ Hz	54	60		dB
V_d	Dropout Voltage	$I_o = 1$ A $T_j = 25$ °C $\Delta V_o = 100$ mV		1.1		V
I_{sc}	Short Circuit Current			1.3		A
I_{scp}	Short Circuit Peak Current	$T_j = 25$ °C		2.2		A

* Load and line regulation are specified at constant junction temperature. Changes in V_o due to heating effects must be taken into account separately. Pulse testing with low duty cycle is used.

L7900AB/AC SERIES

ELECTRICAL CHARACTERISTICS FOR L7918A (refer to the test circuits, $T_j = 0$ to 125 °C, $V_i = -27V$, $I_o = 500$ mA, $C_i = 2.2$ μF , $C_o = 1$ μF unless otherwise specified)

Symbol	Parameter	Test Conditions	Min.	Typ.	Max.	Unit
V_o	Output Voltage	$T_j = 25$ °C	-17.64	-18	-18.36	V
V_o	Output Voltage	$I_o = -5$ mA to -1 A $P_o \leq 15$ W $V_i = -22$ to -33 V	-17.3	-18	-18.7	V
ΔV_o^*	Line Regulation	$V_i = -21$ to -33 V $T_j = 25$ °C $V_i = -24$ to -30 V $T_j = 25$ °C			360 180	mV mV
ΔV_o^*	Load Regulation	$I_o = 5$ to 1500 mA $T_j = 25$ °C $I_o = 250$ to 750 mA $T_j = 25$ °C			360 180	mV mV
I_d	Quiescent Current	$T_j = 25$ °C			3	mA
ΔI_d	Quiescent Current Change	$I_o = 5$ to 1000 mA			0.5	mA
ΔI_d	Quiescent Current Change	$V_i = -22$ to -33 V			1	mA
$\frac{\Delta V_o}{\Delta T}$	Output Voltage Drift	$I_o = 5$ mA		-1		mV/°C
e_N	Output Noise Voltage	$B = 10$ Hz to 100 KHz $T_j = 25$ °C		300		μV
SVR	Supply Voltage Rejection	$\Delta V_i = 10$ V $f = 120$ Hz	54	60		dB
V_d	Dropout Voltage	$I_o = 1$ A $T_j = 25$ °C $\Delta V_o = 100$ mV		1.1		V
I_{sc}	Short Circuit Current			1.1		A
I_{scp}	Short Circuit Peak Current	$T_j = 25$ °C		2.2		A

ELECTRICAL CHARACTERISTICS FOR L7920A (refer to the test circuits, $T_j = 0$ to 125 °C, $V_i = -29V$, $I_o = 500$ mA, $C_i = 2.2$ μF , $C_o = 1$ μF unless otherwise specified)

Symbol	Parameter	Test Conditions	Min.	Typ.	Max.	Unit
V_o	Output Voltage	$T_j = 25$ °C	-19.6	-20	-20.4	V
V_o	Output Voltage	$I_o = -5$ mA to -1 A $P_o \leq 15$ W $V_i = -24$ to -35 V	-19.2	-20	-20.8	V
ΔV_o^*	Line Regulation	$V_i = -23$ to -35 V $T_j = 25$ °C $V_i = -26$ to -32 V $T_j = 25$ °C			400 200	mV mV
ΔV_o^*	Load Regulation	$I_o = 5$ to 1500 mA $T_j = 25$ °C $I_o = 250$ to 750 mA $T_j = 25$ °C			400 200	mV mV
I_d	Quiescent Current	$T_j = 25$ °C			3	mA
ΔI_d	Quiescent Current Change	$I_o = 5$ to 1000 mA			0.5	mA
ΔI_d	Quiescent Current Change	$V_i = -24$ to -35 V			1	mA
$\frac{\Delta V_o}{\Delta T}$	Output Voltage Drift	$I_o = 5$ mA		-1.1		mV/°C
e_N	Output Noise Voltage	$B = 10$ Hz to 100 KHz $T_j = 25$ °C		350		μV
SVR	Supply Voltage Rejection	$\Delta V_i = 10$ V $f = 120$ Hz	54	60		dB
V_d	Dropout Voltage	$I_o = 1$ A $T_j = 25$ °C $\Delta V_o = 100$ mV		1.1		V
I_{sc}	Short Circuit Current			0.9		A
I_{scp}	Short Circuit Peak Current	$T_j = 25$ °C		2.2		A

* Load and line regulation are specified at constant junction temperature. Changes in V_o due to heating effects must be taken into account separately. Pulse testing with low duty cycle is used.

ELECTRICAL CHARACTERISTICS FOR L7922A (refer to the test circuits, $T_j = 0$ to 125 °C, $V_i = -31V$, $I_o = 500$ mA, $C_i = 2.2$ μF , $C_o = 1$ μF unless otherwise specified)

Symbol	Parameter	Test Conditions	Min.	Typ.	Max.	Unit
V_o	Output Voltage	$T_j = 25$ °C	-21.5	-22	-22.5	V
V_o	Output Voltage	$I_o = -5$ mA to -1 A $P_o \leq 15$ W $V_i = -26$ to -37 V	-21.1	-22	-22.9	V
ΔV_o^*	Line Regulation	$V_i = -25$ to -37 V $T_j = 25$ °C $V_i = -28$ to -34 V $T_j = 25$ °C			440 220	mV mV
ΔV_o^*	Load Regulation	$I_o = 5$ to 1500 mA $T_j = 25$ °C $I_o = 250$ to 750 mA $T_j = 25$ °C			440 220	mV mV
I_d	Quiescent Current	$T_j = 25$ °C			3	mA
ΔI_d	Quiescent Current Change	$I_o = 5$ to 1000 mA			0.5	mA
ΔI_d	Quiescent Current Change	$V_i = -26$ to -37 V			1	mA
$\frac{\Delta V_o}{\Delta T}$	Output Voltage Drift	$I_o = 5$ mA		-1.1		mV/°C
e_N	Output Noise Voltage	$B = 10$ Hz to 100 KHz $T_j = 25$ °C		375		μV
SVR	Supply Voltage Rejection	$\Delta V_i = 10$ V $f = 120$ Hz	54	60		dB
V_d	Dropout Voltage	$I_o = 1$ A $T_j = 25$ °C $\Delta V_o = 100$ mV		1.1		V
I_{sc}	Short Circuit Current			1.1		A
I_{scp}	Short Circuit Peak Current	$T_j = 25$ °C		2.2		A

ELECTRICAL CHARACTERISTICS FOR L7924A (refer to the test circuits, $T_j = 0$ to 125 °C, $V_i = -33V$, $I_o = 500$ mA, $C_i = 2.2$ μF , $C_o = 1$ μF unless otherwise specified)

Symbol	Parameter	Test Conditions	Min.	Typ.	Max.	Unit
V_o	Output Voltage	$T_j = 25$ °C	-23.5	-24	-24.5	V
V_o	Output Voltage	$I_o = -5$ mA to -1 A $P_o \leq 15$ W $V_i = -27$ to -38 V	-23	-24	-25	V
ΔV_o^*	Line Regulation	$V_i = -27$ to -38 V $T_j = 25$ °C $V_i = -30$ to -36 V $T_j = 25$ °C			480 240	mV mV
ΔV_o^*	Load Regulation	$I_o = 5$ to 1500 mA $T_j = 25$ °C $I_o = 250$ to 750 mA $T_j = 25$ °C			480 240	mV mV
I_d	Quiescent Current	$T_j = 25$ °C			3	mA
ΔI_d	Quiescent Current Change	$I_o = 5$ to 1000 mA			0.5	mA
ΔI_d	Quiescent Current Change	$V_i = -27$ to -38 V			1	mA
$\frac{\Delta V_o}{\Delta T}$	Output Voltage Drift	$I_o = 5$ mA		-1		mV/°C
e_N	Output Noise Voltage	$B = 10$ Hz to 100 KHz $T_j = 25$ °C		400		μV
SVR	Supply Voltage Rejection	$\Delta V_i = 10$ V $f = 120$ Hz	54	60		dB
V_d	Dropout Voltage	$I_o = 1$ A $T_j = 25$ °C $\Delta V_o = 100$ mV		1.1		V
I_{sc}	Short Circuit Current			1.1		A
I_{scp}	Short Circuit Peak Current	$T_j = 25$ °C		2.2		A

* Load and line regulation are specified at constant junction temperature. Changes in V_o due to heating effects must be taken into account separately. Pulse testing with low duty cycle is used.

L7900AB/AC SERIES

APPLICATION INFORMATION

Figure 1 : Fixed Output Regulator.

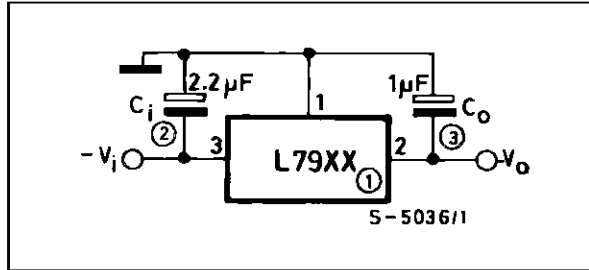

- Notes :**
1. To specify an output voltage, substitute voltage value for "XX".
 2. Required for stability. For value given, capacitor must be solid tantalum. If aluminium electrolytics are used, at least ten times value shown should be selected, Ci is required if regulator is located an appreciable distance from power supply filter.
 3. To improve transient response. If large capacitors are used, a high current diode from input to output (1N4001 or similar) should be introduced to protect the device from momentary input short circuit.

Figure 2 : Split Power Supply ($\pm 15V/1A$).

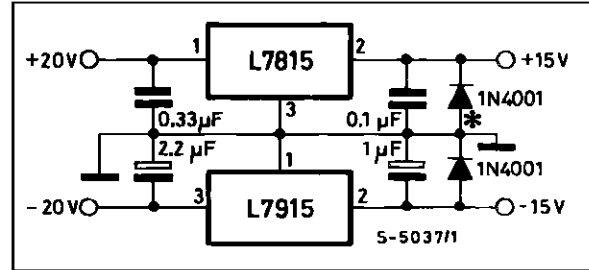

* Against potential latch-up problems.

Figure 3 : Circuit for Increasing Output Voltage.

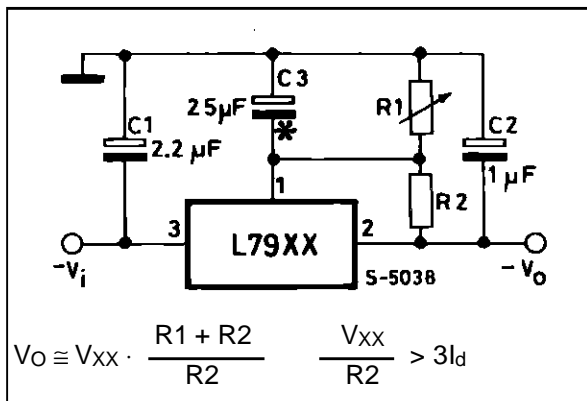

* C3 Optional for improved transient response and ripple rejection.

Figure 4 : High Current Negative Regulator ($-5V/4A$ with 5A current limiting).

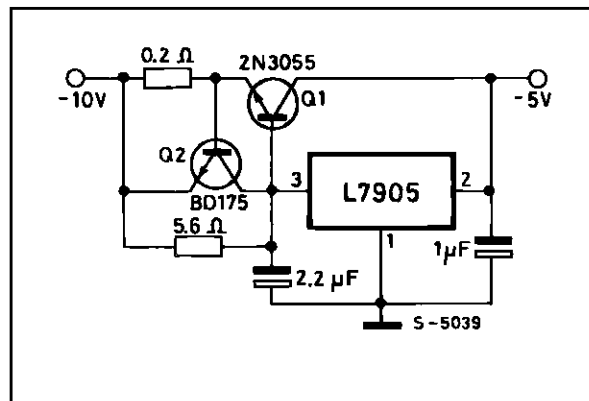
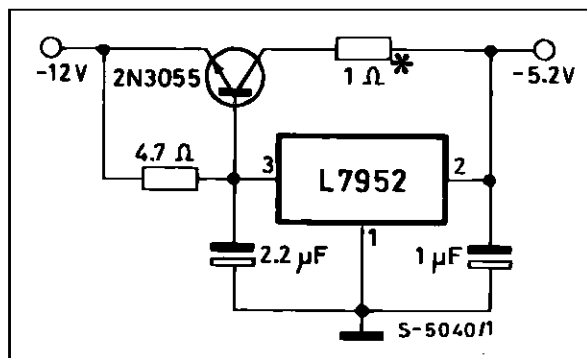

Figure 5 : Typical ECL System Power Supply ($-5.2V/4A$).



* Optional dropping resistor to reduce the power dissipated in the boost transistor.

TO-220 MECHANICAL DATA

DIM.	mm			inch		
	MIN.	TYP.	MAX.	MIN.	TYP.	MAX.
A	4.40		4.60	0.173		0.181
C	1.23		1.32	0.048		0.051
D	2.40		2.72	0.094		0.107
D1		1.27			0.050	
E	0.49		0.70	0.019		0.027
F	0.61		0.88	0.024		0.034
F1	1.14		1.70	0.044		0.067
F2	1.14		1.70	0.044		0.067
G	4.95		5.15	0.194		0.203
G1	2.4		2.7	0.094		0.106
H2	10.0		10.40	0.393		0.409
L2		16.4			0.645	
L4	13.0		14.0	0.511		0.551
L5	2.65		2.95	0.104		0.116
L6	15.2		15.9	0.598		0.625
L7	6.2		6.6	0.244		0.260
L9	3.5		4.2	0.137		0.165
DIA.	3.75		3.85	0.147		0.151

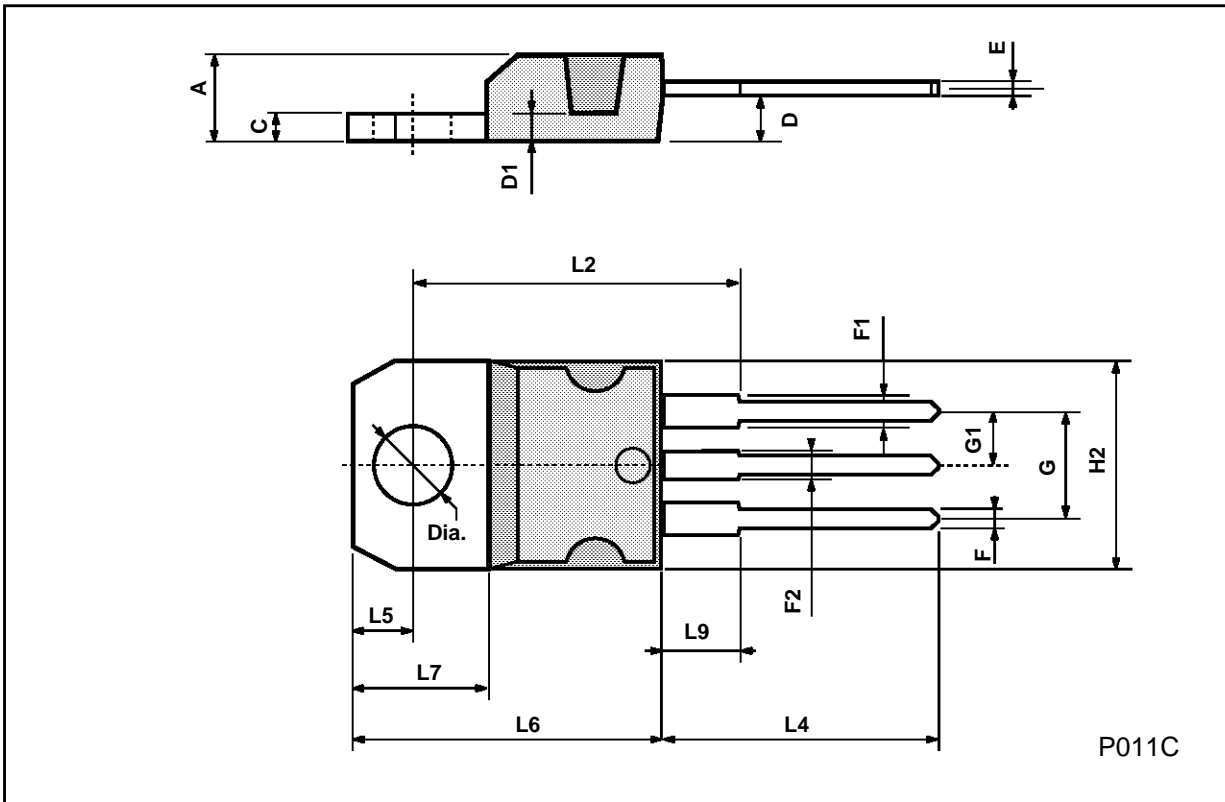

P011C

L7900AB/AC SERIES

Information furnished is believed to be accurate and reliable. However, SGS-THOMSON Microelectronics assumes no responsibility for the consequences of use of such information nor for any infringement of patents or other rights of third parties which may result from its use. No license is granted by implication or otherwise under any patent or patent rights of SGS-THOMSON Microelectronics. Specifications mentioned in this publication are subject to change without notice. This publication supersedes and replaces all information previously supplied. SGS-THOMSON Microelectronics products are not authorized for use as critical components in life support devices or systems without express written approval of SGS-THOMSON Microelectronics.

© 1994 SGS-THOMSON Microelectronics - All Rights Reserved

SGS-THOMSON Microelectronics GROUP OF COMPANIES

Australia - Brazil - France - Germany - Hong Kong - Italy - Japan - Korea - Malaysia - Malta - Morocco - The Netherlands -
Singapore - Spain - Sweden - Switzerland - Taiwan - Thailand - United Kingdom - U.S.A